

RAY M. MARSTON

WE WILL LOOK AT LIGHT-SENSITIVE devices in this article and find out how they can be used in various practical control circuits. Light-sensitive devices include photocells, photodiodes, and phototransistors. Visible and infrared light (or the absence of that light) can trigger many different kinds of circuits for the control of alarms, lights, motors, relays, and other actuators. Light-sensitive devices, sometimes called photoelectric transducers, alter their electrical characteristics in the presence of visible or infrared light.

Photocell basics.

Photocells are also called by many other names including photoconductive cells, light-dependent resistors (LDR's), and photoresistors. They are variable resistors with an extremely wide range of resistance values (up to hundreds of orders of magnitude) that are dependent on the level of incident light. Resistance in photocells varies inversely with the strength of light that falls on them. In other words, resistance is very high in the dark, but low under bright light.

Figure 1 is a cutaway view of a typical photocell showing the pattern of photoconductive material deposited in the serpentine slot separating the two electrodes that have been formed on a ceramic insulating substrate. This pattern maximizes contact between the crystalline photoconductive material and the adjacent metal electrodes.

The photoconductive material is typically cadmium sulfide (CdS) or cadmium selenide (CdSe). The selection of the material and the thickness and width of its deposition determine the resistance value and power rating of the device. The two-terminal assembly is enclosed in a metal or opaque plastic case with a clear glass or plastic window over the photoconductive material. Figure 2 is the schematic symbol for the photocell.

PHOTOSENSITIVE DEVICES

Learn to use photoconductive cells, photodiodes, and phototransistors in practical light-controlled circuits.

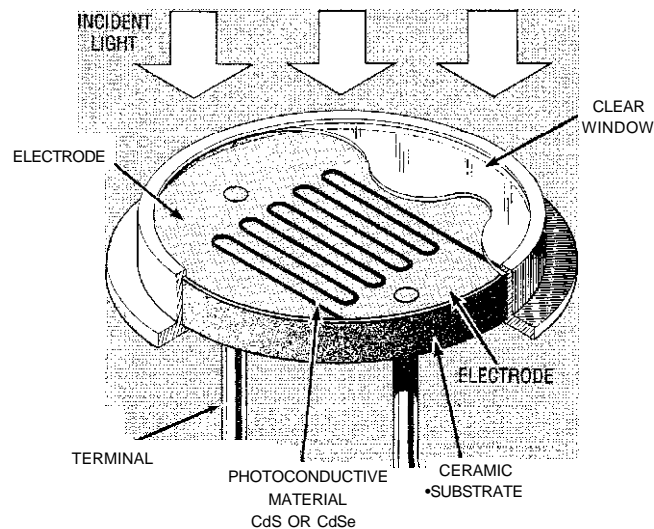

FIG. 1—CUTAWAY VIEW of a photocell or light-dependent resistor (LDR).

Photocells are made with diameters from about one-eighth inch (3 mm) to over one inch (25 mm); the most popular devices have diameters of about three-eighth inch (10 mm). The smaller units are suitable for applications where space is limited, such as in card-reading applications, but they have low power-dissipation ratings. Some photocells are hermetically sealed to withstand the effects of demanding environments.

Figure 3 compares the response of photosensitive devices characteristics with that of the human eye. Relative spectral response is plotted against wavelength from 300 to 1200 nanometers (nm). The bell-shaped human eye response curve shows that the eye is sensitive to a relatively narrow band of the electromagnetic spectrum, between about 400

and 750 nm. The curve peaks in the green light region at about 550 nm and extends down into the violet region (400 to 450 nm) at one end, and up into the dark red light region (700 to 780 nm) at the other end.

Figure 3 shows why cadmium sulfide (CdS) photocells are so popular for light-controlled circuits; the CdS spectral response curve peaks near 600 nm, and it

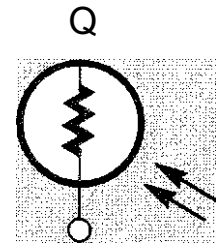

FIG. 2—SCHEMATIC SYMBOL of a photocell.

closely matches that of the human eye. By contrast, the response curve for cadmium selenide (CdSe) peaks further out at about 720 nm. However, CdSe is also sensitive to most of the visible-light region.

A typical CdS photocell characteristic curve is shown in Fig. 4. Its dark resistance is about five megohms. This value falls to about 600 ohms at a light intensity of 100 lux, typical of a well illuminated room and

to about 30 ohms at an intensity of 8000 lux, typical of bright sunlight. (The lux is the SI unit of illuminance produced by a luminous flux of 1 lumen uniformly distributed over a surface of 1 square meter.)

Commercial photocells have good power and voltage ratings, similar to those of conventional resistors. Power dissipation ratings could be between 50 and 500 milliwatts, depending on detector material. Their only

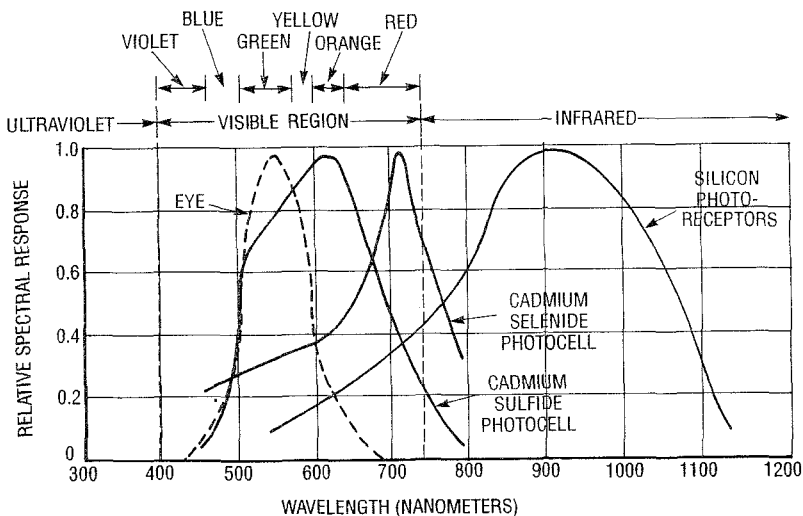

FIG. 3—CHARACTERISTIC CURVES of photosensitive devices compared with the response curve of the human eye.

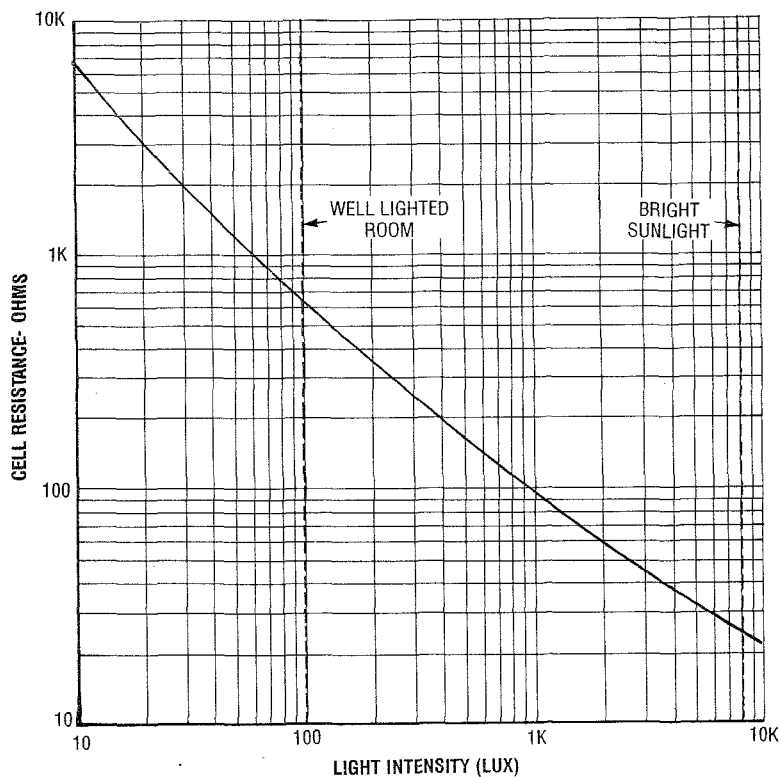

FIG. 4—CURVE OF RESISTANCE versus light intensity for a typical photocell with a 10-mm face diameter.

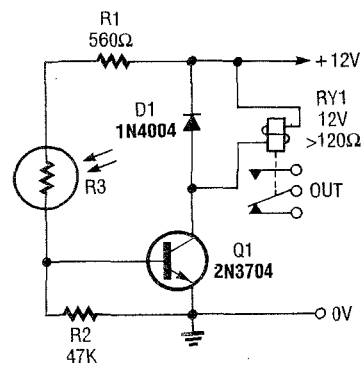

FIG. 5—SIMPLE NON-LATCHING light-activated relay switch.

significant drawbacks are their slow response times. Cadmium-selenide photocells generally have shorter time constants than cadmium-sulfide photocells (approximately 10 milliseconds versus 100 milliseconds). They also offer lower resistance values, higher sensitivities, and higher temperature coefficients of resistance.

Photocells are included in photographic exposure meters, light- and dark-activated switches for controlling safety lights, and intrusion alarms. Some light-activated alarms are triggered by breaking a light beam. There are even light-reflective smoke alarms based on photocells. Figures 5 to 20 show practical photocell circuits; each will work with almost any photocell.

Photocell light switches

Figures 5 to 10 illustrate practical light-activated switch circuits with relay contact outputs that are based on the photocell. The simple circuit shown in Fig. 5 is designed to react when light enters a normally dark space such as the inside of a cabinet or closet. The photocell R1 and resistor R2 form a voltage divider that sets the base bias of Q1. Under dark conditions, the photocell has a high resistance, so zero bias is applied to the base of Q1; in this state, Q1 and the relay RY1 are off. When a sufficient amount of light falls on the photocell, its resistance drops to a low value, and bias is applied to the base of Q1. That bias activates RY1, and its contacts can control external circuitry.

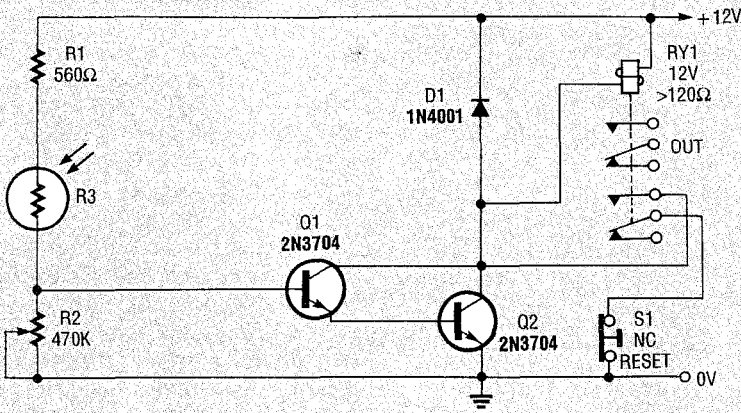

FIG. 6—SENSITIVE SELF-LATCHING light-activated relay switch.

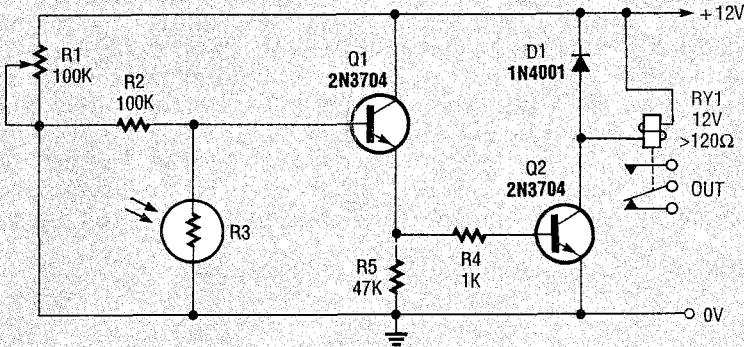

FIG. 7—SIMPLE DARK-ACTIVATED relay switch.

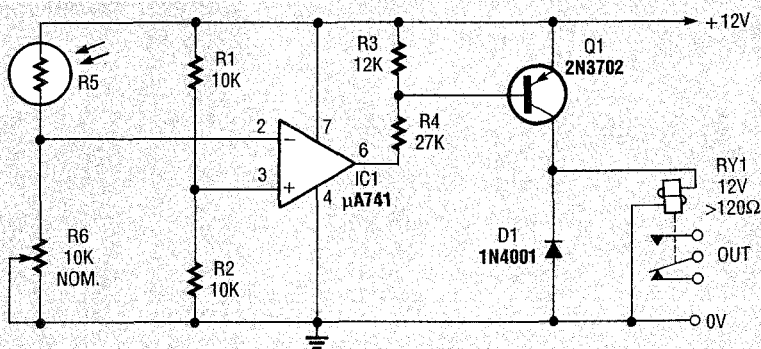

FIG. 8—PRECISION LIGHT-sensitive relay switch. R5 equals R6 at normal light level.

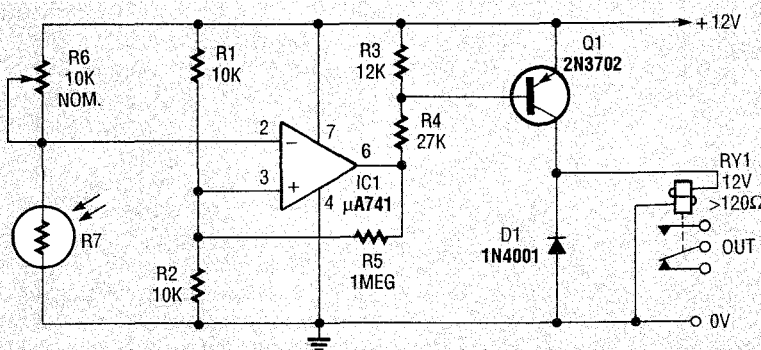

FIG. 9—PRECISION DARK-ACTIVATED switch with hysteresis. R6 equals R7 at normal light level.

The simple Fig. 5 circuit has low sensitivity and no provision

for sensitivity adjustment. Figure 6 illustrates how these

drawbacks can be overcome with Darlington-coupled transistors Q1 and Q2 replacing Q1, and the use of a potentiometer R2 for sensitivity control, replacing fixed resistor R2. The diagram also shows how the circuit can be made self-latching with the second set of relay contacts. Normally-closed pushbutton switch S1 permits the circuit to be reset (unlatched) when required.

Figure 7 shows how a photocell can form a simple dark-activated relay that turns on when the light level falls below a value preset by potentiometer R1. Resistor R2 and the photocell R3 form a voltage divider. The voltage at the R2-R3 junction increases with falling light. That voltage, buffered by emitter-follower Q1, controls relay RY1 with common-emitter amplifier Q2 and current-limiting resistor R4.

The light trigger or threshold levels of the circuits shown in Figs. 6 and 7 are susceptible to variations in supply voltage and ambient temperature. Figure 8 shows a very sensitive precision light-activated circuit that is not influenced by those variables. In this circuit the photocell R5, potentiometer R6, and resistors R1 and R2 are connected to form a Wheatstone bridge, and op-amp IC1 and the combination of transistor Q1 and RY1 act as a highly sensitive balance-detecting switch. The bridge balance point is independent of variations in supply voltage and temperature, and is influenced only by variations in the relative values of the bridge components.

In Fig. 8, the photocell R5 and potentiometer R6 form one arm of the bridge, and R1 and R2 form the other arm. Those arms can be considered as voltage dividers. The R1-R2 arm applies a fixed half-supply voltage to the non-inverting input of the op-amp, while the photocell-potentiometer divider applies a light-dependent variable voltage to the inverting pin of the op-amp.

To use this circuit, potentiometer R6 is adjusted so that the voltage across the photocell and the potentiometer rises

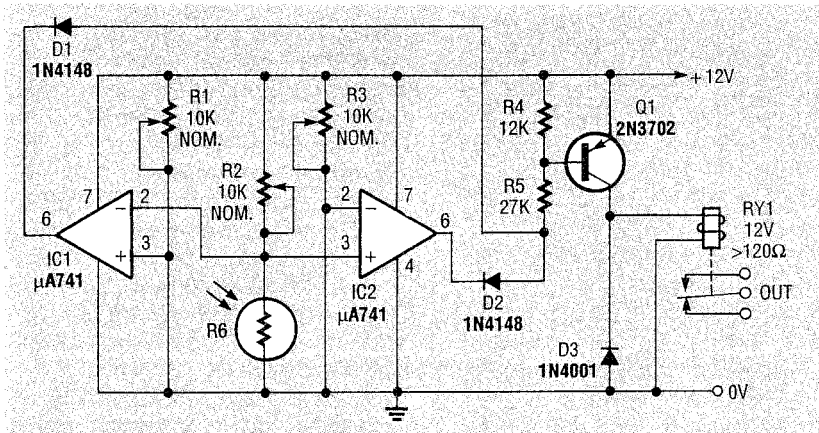

FIG. 10—COMBINED LIGHT/DARK-activated switch with a single relay output. Value of R2 equals R6 at normal light level.

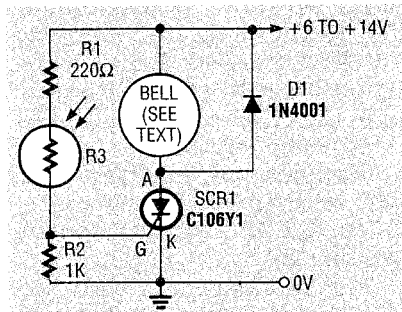

FIG. 11—SIMPLE LIGHT-ACTIVATED alarm bell.

fractionally above that across R1 and R2 as the light intensity rises to the desired trigger level. Under that condition, the op-amp output switches to negative saturation, which turns on Q1 and thus RY1. When the light intensity falls below that level, the op-amp output switches to positive saturation, and Q1 and the relay are turned off.

The circuit in Fig. 8 is so sensitive that it is able to respond to

changes in light-level that are too small to be detected by the human eye. The circuit can be modified to act as a precision dark-activated switch by either transposing the inverting and non-inverting input pins of the op-amp, or by transposing the

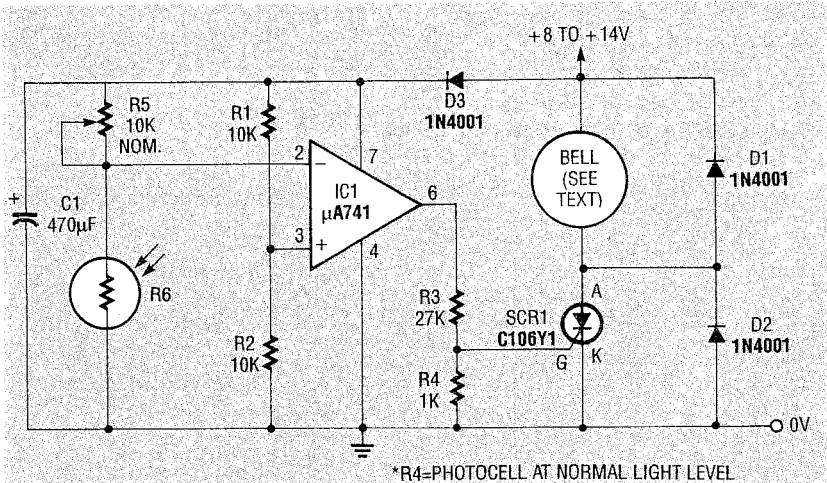

FIG. 13—PRECISION LIGHT-ACTIVATED alarm bell. Value of R5 equals R6 at normal light level.

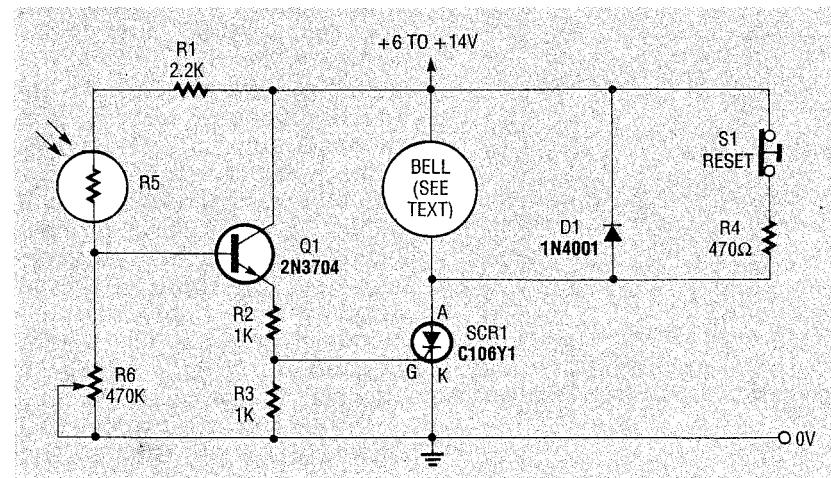

FIG. 12—IMPROVED LIGHT-ACTIVATED alarm bell with self-latching.

photocell and the adjacent potentiometer.

The circuit in Fig. 9 also shows how a small amount of hysteresis can be added to the circuit with the feedback resistor R5 so that relay RY1 is actuated when the light level falls to a preset value. However, the relay is not de-actuated again until the light intensity increases substantially above that value. The hysteresis magnitude is inversely proportional to the value of R5, but it is zero when R5 is open circuited.

Figure 10 shows how a precision light/dark switch can be made by combining op-amp light and dark switches. The switch activates relay RY1 if the light intensity rises above one preset value or falls below another preset value. Potentiometer R1 controls the dark level, potentiometer R2 controls the

supply voltage, and potentiometer R3 controls the light level.

To organize the circuit shown in Fig. 10, first preset potentiometer R2 so that about half the supply voltage appears at the junction between photocell R6 and potentiometer R2 when the photocell is illuminated at its normal intensity level. Potentiometer R1 can then be preset so that RY1 is actuated when the light intensity falls to the desired dark level, and potentiometer R3 can be adjusted so that RY1 is actuated at the desired brightness level.

In the circuits shown in Figs.

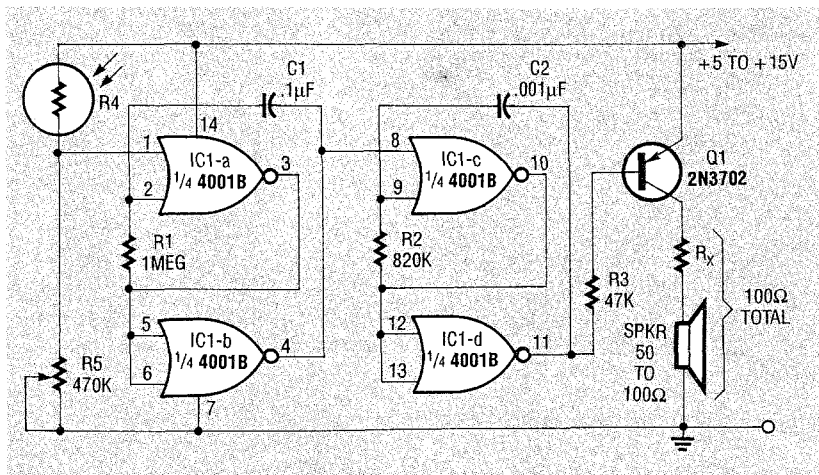

FIG. 14—DARK-ACTIVATED ALARM with pulsed-tone output.

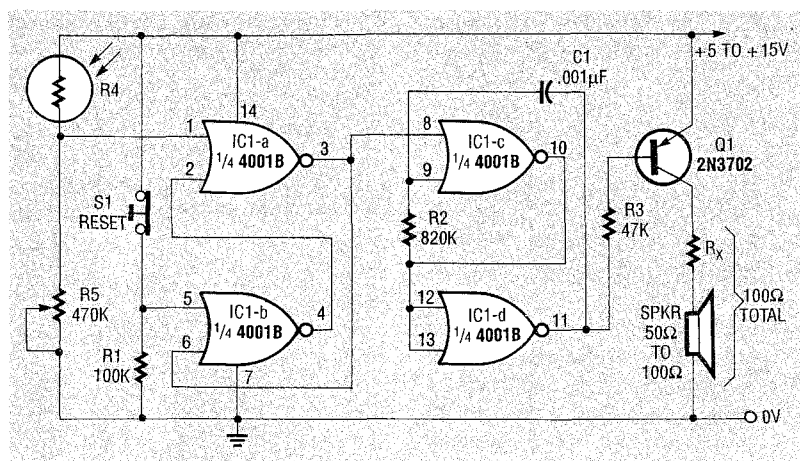

FIG. 15—SELF-LATCHING LIGHT-activated alarm with monotone output.

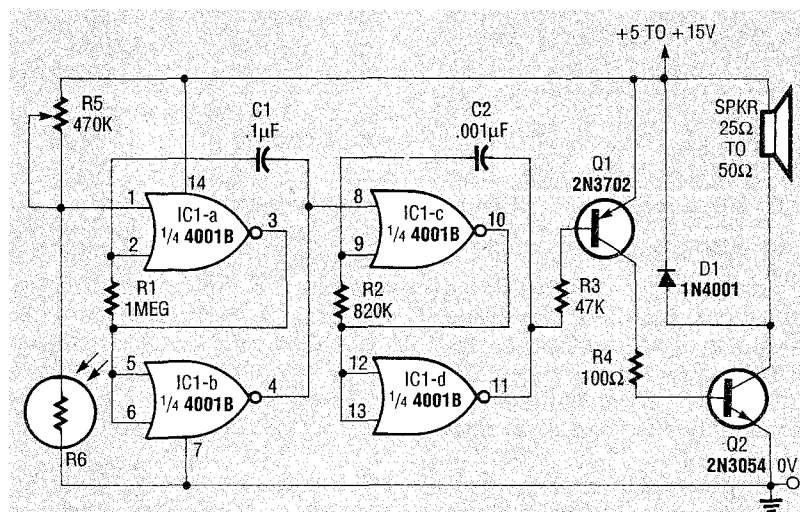

FIG. 16—BOOSTED-OUTPUT PULSED-tone light-activated alarm.

8 to 10, the resistance values of the series potentiometers should equal the photocell's resistance values at the normal light level of each circuit.

Bell-output photocell alarms

The light-activated photocell

circuits in Figs. 5 to 10 all have relay outputs that can control many different kinds of external circuits. In many light-activated circuit applications, however, the circuits must trigger audible alarms. This response can also be obtained without re-

lays as shown in Figs. 11 to 17.

Figure 11 shows a simple light-activated alarm circuit with a direct output to an alarm bell or buzzer. The bell or buzzer must be self-interrupting and have an operating current rating less than 2 amperes. The supply voltage should be 1.5 to 2 volts greater than the nominal operating value of the bell or buzzer. Photocell R3 and resistor R2 form a voltage divider. Under dark conditions, the photocell resistance is high, so the voltage at the junction R3 and R2 is too small to activate the gate of the silicon-controlled rectifier SCR1. Under bright light conditions with the photocell resistance low, gate bias is applied to the SCR which turns on and activates the alarm.

In the circuit of Fig. 11, keep in mind that although the SCR is self-latching, the fact that the alarm is self-interrupting ensures that the SCR repeatedly unlatches automatically as the alarm sounds. (The SCR anode current falls to zero in each self-interrupt phase.) Consequently, the alarm automatically turns off again when the light level falls below the circuit's threshold level.

The circuit of Fig. 11 has fairly low sensitivity and no sensitivity adjustment. Figure 12 shows how that drawback can be overcome: Potentiometer R6 replaces a fixed resistor and Q1 is inserted as a buffer between photocell R5 and the SCR1 gate. The diagram also shows how to make the circuit self-latching by wiring R4 in parallel with the alarm so the SCR anode current remains above zero as the alarm self-interrupts. Switch S1 permits the circuit to be reset (unlatched) when required.

Figure 13 shows how to make a precision light-alarm with an SCR-actuated output based on a Wheatstone bridge formed by the photocell R6, potentiometer R5, and op-amp IC1. The op-amp balance detector provides precision control. That circuit can be converted into a dark-activated alarm by simply transposing the photocell and potentiometer. Hysteresis can also be added, if required.

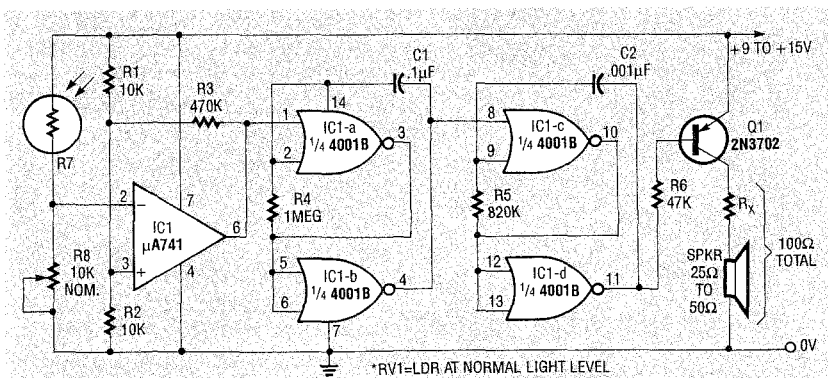

FIG. 17—PRECISION LIGHT-activated pulsed-tone alarm with hysteresis. Value of R7 equals R8 at normal light level.

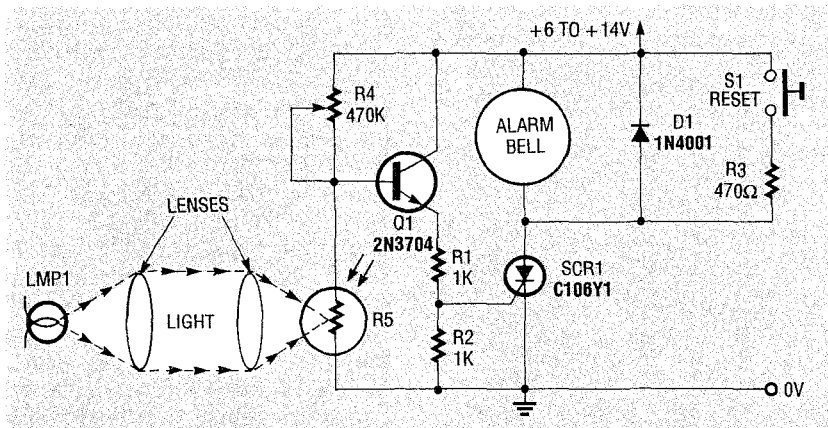

FIG. 18—SIMPLE LIGHT-BEAM alarm with self-interrupting bell output.

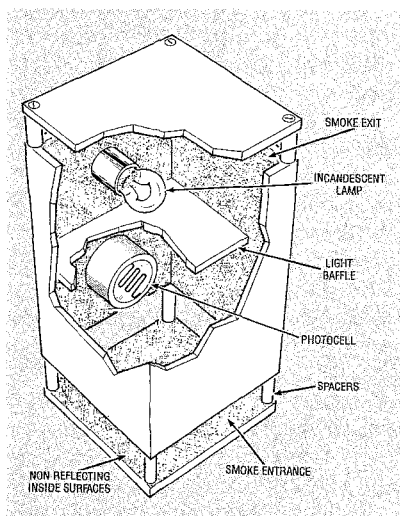

FIG. 19—CUTAWAY VIEW of a light-reflection smoke detector.

Speaker-output alarms

Figures 14 to 17 show different ways of using CMOS 4001B quad 2-input NOR-gate ICs to make light-activated alarms that generate audible outputs with loud speakers. The 4001B is available as the CD4001B from Harris and from Motorola. National Semicon-

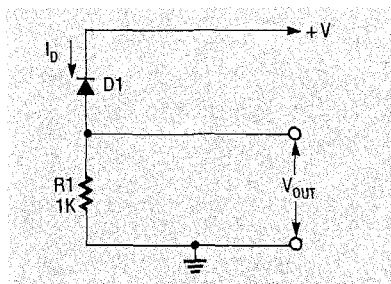

FIG. 20—REVERSE-BIASED DIODE circuit.

ductor, Signetics and others under various designations that include 4001B.

The circuit of Fig. 14 is a dark-activated alarm circuit that generates a low-power 800-Hz pulsed-tone signal at the speaker. NOR gates IC1-c and IC1-d are wired as an 800-Hz astable multivibrator that can feed tone signals into the speaker from Q1. It is gated on only when the output of IC1-b is low. NOR gates IC1-a and IC1-b are wired as a 6-Hz astable circuit that is gated on only when its gate pin 1 is pulled low. (Pin 1 is coupled to the voltage divider formed by photocell

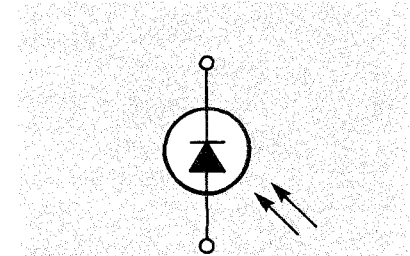

FIG. 21—SCHEMATIC SYMBOL for a photodiode.

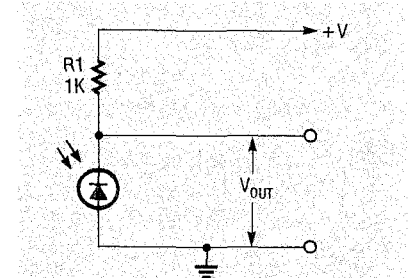

FIG. 22—PHOTODIODE WITH resistor between diode and supply.

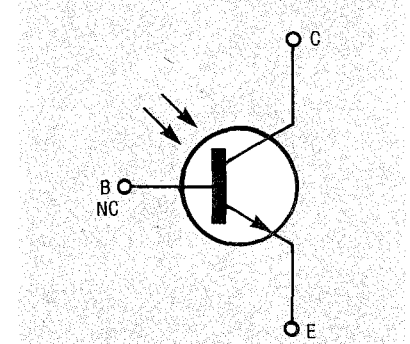

FIG. 23—SCHEMATIC SYMBOL for a phototransistor.

R4 and potentiometer R5.)

The action of the circuit is as follows: Under bright light conditions, the voltage at the junction of the photocell R4 and potentiometer R5 voltage is high, so both astable circuits are disabled and no output is generated at the speaker. Under dark conditions, the photocell-potentiometer junction voltage is low, so the 6-Hz astable circuit is activated, gating the 800-Hz astable circuit on and off at a 6-Hz rate. As a result, a signal from Q1 produces a pulsed-tone in the speaker.

The precise gating level of the 4001B IC is determined by its threshold voltage value, which is a fraction of the supply voltage—nominally 50%. That val-

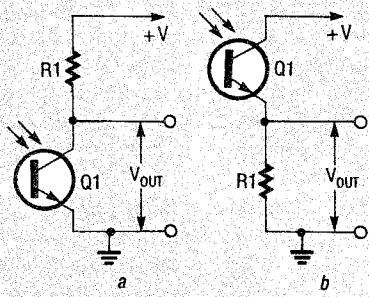

FIG. 24—ALTERNATIVE PHOTOTRANSISTOR circuits.

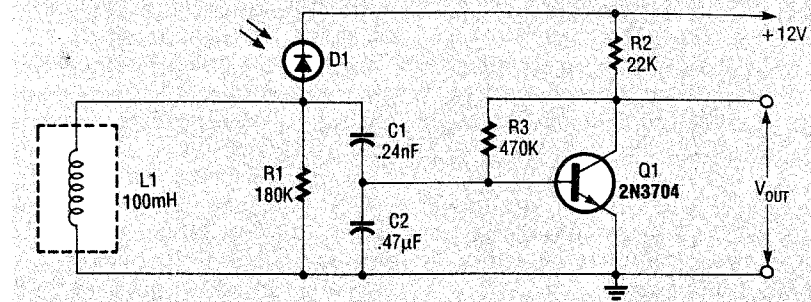

FIG. 28—SELECTIVE INFRARED preamplifier for 30-Hz operation.

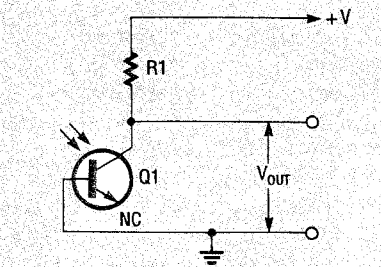

FIG. 25—PHOTOTRANSISTOR used as a photodiode.

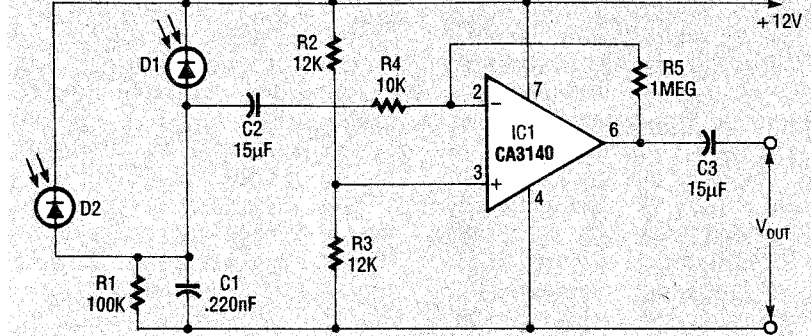

FIG. 29—SELECTIVE PREAMPLIFIER for 20-kHz light-beam alarms.

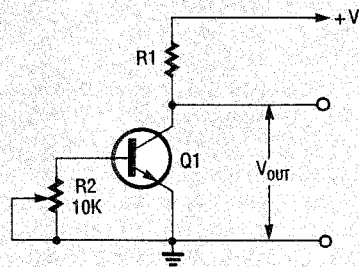

FIG. 26—VARIABLE-SENSITIVITY phototransistor circuit.

gated 800-Hz astable circuit, but IC1-a and IC1-b are wired as a bistable multivibrator with a normally high output. Under bright light conditions, the photocell-potentiometer junction goes high and latches the bistable circuit into its alternative state. As a result, the 800-Hz astable circuit is gated on to generate the monotone alarm signal. The circuit remains in that state until dark conditions return, and the bistable circuit is simultaneously reset with S1.

The light/dark operation of the circuits in Figs. 14 and 15 can be reversed by transposing the positions of the photocell and potentiometer. Each circuit produces only a few milliwatts of output power. Figure 16 shows how the operation of the dark-operated circuit of Fig. 14 can be reversed to become light-operated by switching the positions of the photocell and potentiometer. The output power can be boosted with an additional output transistor Q2. This circuit can operate from a 5- to 15-volt supply and with 25- to 50-ohm speakers. The output power can vary from 0.25 to 11.25 watts, depending on the

voltage and impedance values. The circuits shown in Figs. 14 to 16 have adequate sensitivity levels for most practical applications. However, if required, both sensitivity and trigger-level stability can be increased. That's done in Fig. 17 by inserting an op-amp voltage comparator between the voltage divider junction formed by photocell R7 and potentiometer R8 and gate pin 1 of IC1-a. Resistor R3 controls the hysteresis of the circuit, but it can be removed if hysteresis is not needed.

Selection of photocell circuits

Photocells are widely used in alarms that are triggered by interrupting a visible light beam. They are also used in smoke alarms that are actuated when smoke particulates reflect light back to the photocell. Figures 18 to 20 show self-interrupting alarm-bell versions of those warning circuits.

The interrupted light beam-activated alarm circuit of Fig. 18 acts like a dark-operated alarm. Normally, the photocell is illuminated by the light beam so its resistance is low and only low voltage appears at the junction of potentiometer R4 and pho-

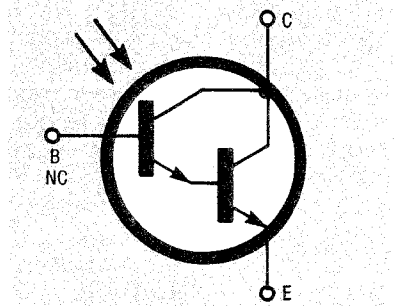

FIG. 27—SCHEMATIC SYMBOL for a photodarlington.

ue might vary from 30% to 70% in individual devices, but gating points of these IC's are generally stable. The Fig. 14 circuit provides sensitive dark-activated alarm triggering.

Figure 15 is a schematic of a self-latching light-activated alarm with an 800-Hz monotone output. In this circuit, IC1-c and IC1-d are also wired as a

tocell R5. Consequently, both the SCR and bell are off. When the light beam is broken, photocell resistance increases and a significantly higher voltage appears at the potentiometer-photocell junction. Under this condition SCR1 conducts and the alarm bell rings. Resistor R3 in series with switch S1 self-latches the alarm.

Figure 19 is a cutaway view of a reflective-type smoke detector. The lamp and photocell are mounted on one wall of the box whose open ends are covered with lids mounted on spacers. The openings provided by the spacers permit smoke to pass through the detector while ambient light is excluded. An internal baffle prevents incandescent lamp light from falling directly on the photocell.

The lamp acts as both a source of light and heat; the heated air in the box rises, creating air convection currents that draw air in at the bottom of the box and expell it from the top. The inside of the box is painted matte black to eliminate reflections.

If the air currents moving through the detector box are free of smoke, no light will fall on the photocell, and its resistance will be very high. However, if the air contains smoke, the particulates of that smoke reflect light from the lamp back onto the photocell face, causing its resistance to decrease sharply. That resistance drop can trigger an alarm. Figure 12 is a practical control circuit that can be used in the smoke alarm shown in Fig. 19.

Photodiodes put to use

If a conventional silicon diode is connected in the reverse-biased circuit of Fig. 20, only leakage current will flow through the diode and no voltage will be developed across resistor R1. However, if the case is removed from a conventional silicon diode to expose its PN junction, and the diode is then replaced in the same circuit, its photosensitive properties can be observed.

When the diode is exposed to light, its current could rise to as

much as one milliamperere, producing a voltage across R1.

All silicon PN junctions are photosensitive. Thus a photodiode is essentially a conventional silicon PN-junction diode in a case with a transparent cover to permit light to reach its junction. Figure 21 shows its standard schematic symbol.

In Fig. 22 the photodiode is reverse biased and its output voltage is taken across a series-connected load resistor R1. That resistor could also be connected between the diode and ground as shown in Fig. 20. Photodiodes also have spectral response characteristics, which are determined by the doping of the semiconductor material.

Figure 3 shows a typical response curve that applies for all silicon photoreceptors, a category which includes both photodiodes and phototransistors.

While silicon photodiodes have lower visible-light sensitivity than either cadmium-sulphide or cadmium-selenide photocells, they respond faster to changes in light level. As stated earlier, cadmium-sulfide and cadmium-selenide photocells are best suited for applications in visible light in which they are directly coupled and where relatively slow response time is acceptable. By contrast, photodiodes are better suited for applications in the infrared region in which they receive AC signals and where fast response is required.

Photodiodes are typically used in infrared remote-control circuits, beam-interruption switches and alarm circuits. However, lead-sulfide (PbS) photocells have characteristics that are similar to those of visible-light photocells except that they function only in the infrared region.

Phototransistors

Figure 23 shows the standard phototransistor symbol. The phototransistor is a silicon bipolar NPN transistor in a case with a transparent cover that allows light to reach its PN junctions. The device is normally used with its base pin open-circuited as shown in both parts of

Fig. 24. In Fig. 24a, the base-collector junction of the phototransistor is effectively reverse-biased so it acts as a photodiode. The light-generated currents of the base-collector junction feed directly into the base of the device, and the normal current-amplification of the transistor causes collector current to flow as the output. That amplified current across R1 produces the output voltage.

Phototransistor collector and emitter currents are usually similar because the base connection is open circuited, and the device is not subjected to negative feedback. As a consequence, the alternative circuit shown as Fig. 24b offers about the same performance as the circuit shown in Fig. 24a. The output voltage appears across R1 which is connected between the emitter and ground.

The sensitivity of a phototransistor is typically one hundred times greater than that of a photodiode. However, its useful maximum operating frequency of a few hundred kilohertz is proportionally lower than that of a photodiode's tens of megahertz. A phototransistor can be converted into a photodiode by connecting it as shown in Fig. 25.

Alternatively, the sensitivity and operating speed of a phototransistor can be made variable by wiring a potentiometer between its base and emitter, as shown in Fig. 26. With R2 open circuited, phototransistor operation is obtained; with R2 short circuited, a photodiode response occurs.

In practical applications of the circuits shown in Figs. 24 through 26, the R1 load value is usually selected as a compromise because voltage gain increases but the useful operating bandwidth decreases with the value of R1. Also, the value of R1 value must, in many applications, be chosen to bring the photosensitive device into its linear operating region.

Darlington phototransistors consist of two transistors coupled as shown in the schematic symbol of Fig. 27. Typical sen-

sivities of photodarlingtons are about ten times greater than those of standard phototransistors, but their useful maximum operating frequencies are only tens of kilohertz.

Preamplifier circuits

Photodiodes and phototransistors are used as lightwave signal receivers or detectors in fiberoptic transmission lines. The light traveling in the optical fiber can be modulated by either analog or digital methods. Photodiodes and phototransistors are also detectors in optocouplers and infrared light-beam interruption switching and alarm-control systems.

In those applications, the signal reaching the photosensor could either be very strong or very weak. Moreover, the photosensor could be subjected to a lot of noise in the form of random, unwanted visible or infrared emissions. To minimize interference problems, optical links are usually operated in the infrared range, and the op-tosensor's output is then processed with a low-noise preamplifier having a wide dynamic operating range. Figures 28 and 29 illustrate typical examples of preamplifier circuits with photodiode sensors.

The Fig. 28 circuit is designed for use with a 30-kilohertz carrier. The tuned circuit, consisting of L1, C1, and C2, is wired in series with D1 and damped by R1 to provide the necessary frequency-selective low-noise response. The output signals are tapped off at the junction between C1 and C2 and then amplified by Q1.

The 20-kilohertz selective preamplifier shown in Fig. 29 is intended for an infrared light-beam alarm. The alarm sounds when the beam is broken. Two IR photodiodes, D1 and D2, are wired in parallel so that the optical signals are lost only when both photodiode signals are cut off. Register R1 is shunted by C1 to reject unwanted high-frequency signals. The output signals across R1 are fed to the inverting op-amp through C2, which rejects unwanted low-frequency signals. **R-E**

BATTERY TESTER

continued from page 62

base terminals of a standard #1157 automotive incandescent lamp and crimping alligator clips to the other ends of the wires. This load can then be clipped across the battery's terminals for several hours. (The assembly is also a handy, inexpensive trouble-shooting light that you can use for working under the hood of your car.) After disconnecting the load, wait until the voltage stabilizes before doing the CCA test. Ideally, the open, circuit voltage of a new battery should be 12.6 volts (± 0.02 volt).

CRAE test procedure

When using CRAE to test a battery, follow these steps:

1. Determine the manufacturer's CCA rating for the battery. This information is a reference that will help you to determine if the battery should be replaced. Also, estimate the ambient temperature of the battery by taking the air temperature of the battery's location immediately before you begin the test.
2. Disconnect the ground cable from the battery if it is connected to the electrical system of a vehicle before doing the test.
3. Using an accurate digital multimeter with a basic DC-voltage accuracy of at least 0.5%, measure the open-circuit voltage of the battery. If the voltage is below 12.25 volts, recharge the battery and recheck the voltage.
4. Under some conditions the battery voltage will exceed 12.65 volts. In that case, discharge it slightly as explained earlier in the text. Because CRAE itself is a light (2.5 ampere) load, it can be used to discharge the battery. However, *Do not use CRAE for sustained periods of more than two minutes because it is not designed for continuous use!* To measure the output of the battery most accurately, the battery's open-circuit voltage should be between 12.4 and 12.6 volts.
5. Connect CRAE's positive

(red) alligator clip to the "+" terminal of the battery and the negative (black) clip to the "-" terminal. Adjust the MAX(INF)ADJ knob on the panel so that the needle points to the maximum deflection. Be sure that all connections are *secure*. A poor alligator clip connection will cause CRAE to give an erroneous reading.

6. Throw switch S1 to the TIMER RESET (left) position and then let it snap back to the center "off" position. Remember that S1 has three positions: center is "off" and the others are momentary action.

7. To test the battery, hold S1 in the TEST position until the LED lights in about 1 minute. When that occurs, take the reading and let S1 return to the center "off" position.

8. For the most accurate retest the battery. Any difference between the first and second readings on a satisfactory battery is insignificant. However, expect that the second reading on a weak battery will be lower than the first. The second reading is the *most accurate*. If you want to retest the battery a third time, be sure to wait at least two minutes between the tests to avoid stressing CRAE.

9. *Do not use the MAX(INF)ADJ knob for the second or subsequent readings on the same battery.* (The 1-minute, 2.5-ampere load of the initial test has changed the battery's open-circuit voltage.) However, if you want to test another battery proceed as stated originally. Also, if the subsequent test on the same battery occurs an hour or more later, reset the meter needle to the INF position. A general rule is that if the open-circuit voltage of the battery is constant—no matter when tested—use the MAX (INF) ADJ knob to set the meter needle to the INF position.

After determining the cranking amp capacity and temperature, use either the GW BASIC program in Table 1 or the graph in Fig.1 to determine the battery's CCA capacity. *Replace the battery if the calculated CCA is substantially lower than the manufacturer's rating.* **R-E**